

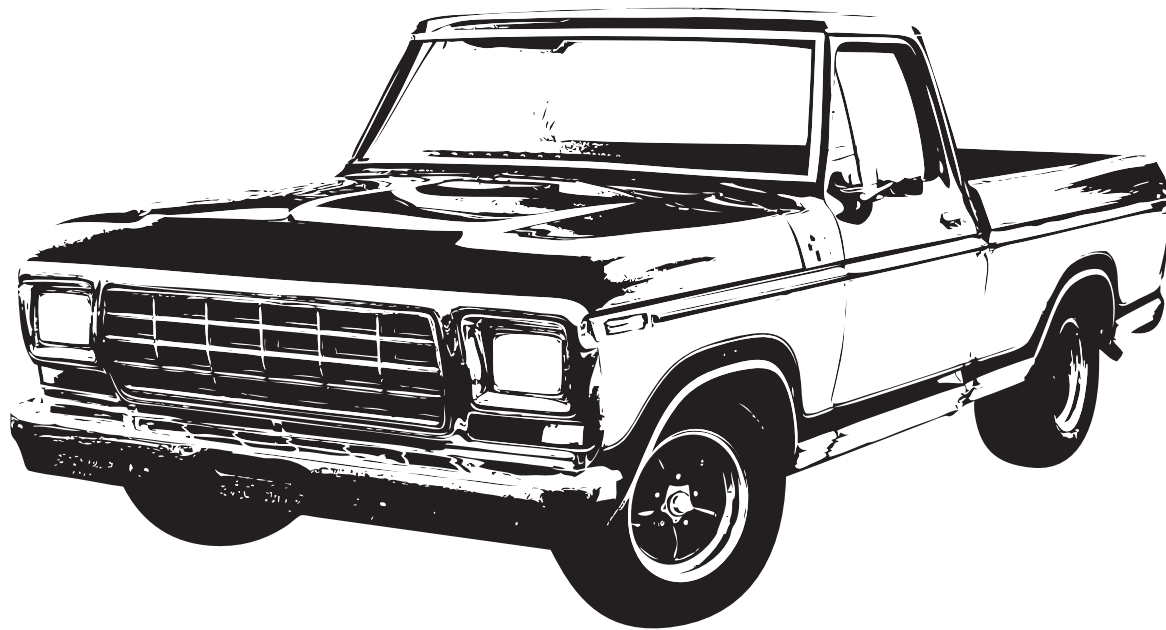

Installation Manual

1976-79 Ford Truck & 78-79 Bronco

Compressor Upgrade Kit - 123-1008 Series





Congratulations...

You have just purchased the highest quality, best performing A/C system upgrade ever designed for your Classic Vehicle.

To obtain the highest level of performance and dependability our systems are known for, please pay close attention to the following instructions. Our installation steps and procedures are derived from a long history of research and development. The combined experience achieved through thousands of successful installations (and feedback from customers like you). Please remember that our #1 goal is that you have a successful installation and a system that performs at a very high level for many years to come.

Before starting, read the instructions carefully, from beginning to end, and follow the proper sequence. On the next page you'll find a safety and general checklist that you should read before starting your installation.

Again, thank you from our entire staff.



PRE-INSTALLATION:

- Before beginning the installation, check the shipping box for the correct components.
- **If your vehicle has been or is being modified, some procedures may need to be adjusted to fit your particular application.**
- A basic cleaning of the engine compartment before beginning will make things go more smoothly.
- Check condition of engine mounts. Excessive engine movement can damage hoses to A/C and/or heater.
- **DISCONNECT THE BATTERY FIRST**
- **DISCHARGE THE SYSTEM NEXT;** You will want to have your system evacuated of all remaining refrigerant according to local laws. An A/C service shop can handle this for you.
- **TOOLS/MATERIALS REQUIRED:** A set of SAE Wrenches & Sockets, (A set of ratcheting wrenches is suggested for the compressor installation), Magnet (Reach Tool), (2x) Medium Adjustable Wrenches, Flat Screwdriver, Wire cutter w/ crimper, and Tape or Caps.

PLEASE NOTE! IN ORDER TO PROTECT NEWLY INSTALLED PARTS, IT'S CRITICAL THAT THE EVAPORATOR, LIQUID LINE, AND CONDENSER IS CLEAN AND FREE OF CONTAMINATION. DAMAGE TO COMPONENTS AS A RESULT OF CONTAMINATION WILL NOT BE COVERED UNDER WARRANTY.

IMPORTANT NOTES:

- Use one or two drops of oil (supplied with your kit) on **ALL** O-rings, and threads.
- All capped fittings **MUST** remain covered until actual connection of the fitting to prevent contamination.
- Use two adjustable wrenches on all O-ring connections, these should be tightened to 10-15 ft/lbs which is hand tight plus ¼ turn. Over tightening could cause splitting of the O-ring.
- Carefully thread fittings. Fittings will thread easily, therefore if there is resistance, back off and re-align to avoid cross-threading. Be careful not to over tighten.

**Should you have any technical questions, call us immediately, we will be glad to assist you.
Our toll-free number is listed on every page, we're here to help!**

YOU CAN NOW BEGIN THE INSTALLATION...



THESE ARE THE PARTS FOR YOUR COMPRESSOR UPGRADE KIT

If your kit happens to arrive incomplete, contact us asap for assistance!

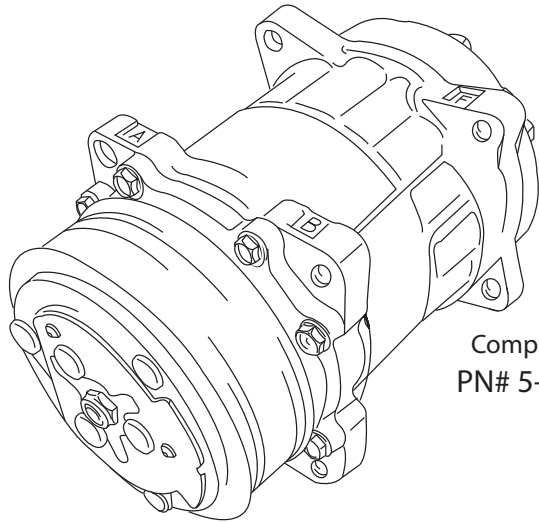

Compressor
PN# 5-128-5

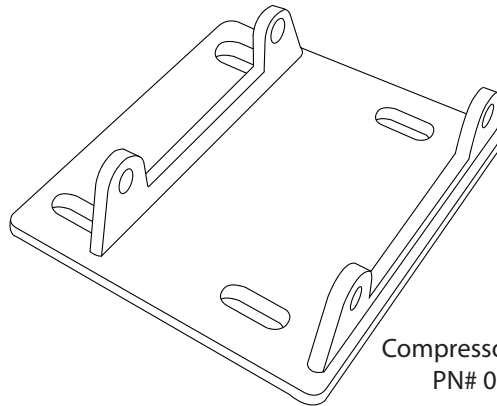

Compressor Adapter
PN# 07-182

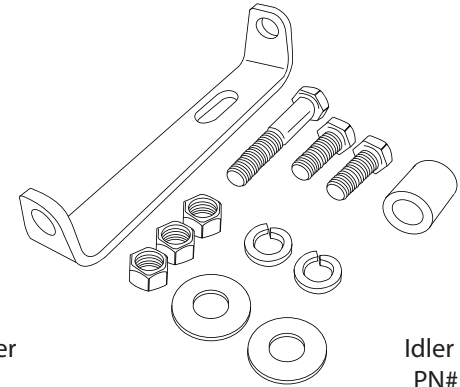

Idler Adapter
PN# 07-183

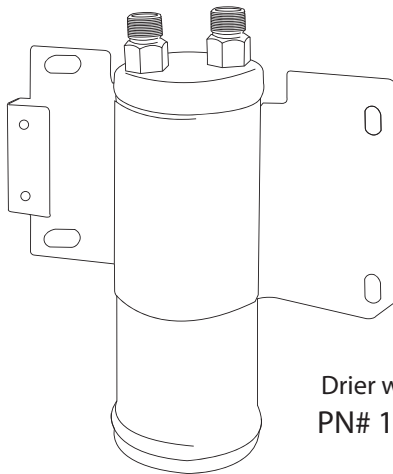

Drier w/ Bracket
PN# 112-1050

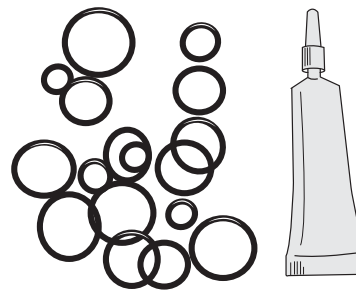

O-Rings and Lubricant Oil
PN# 05-400

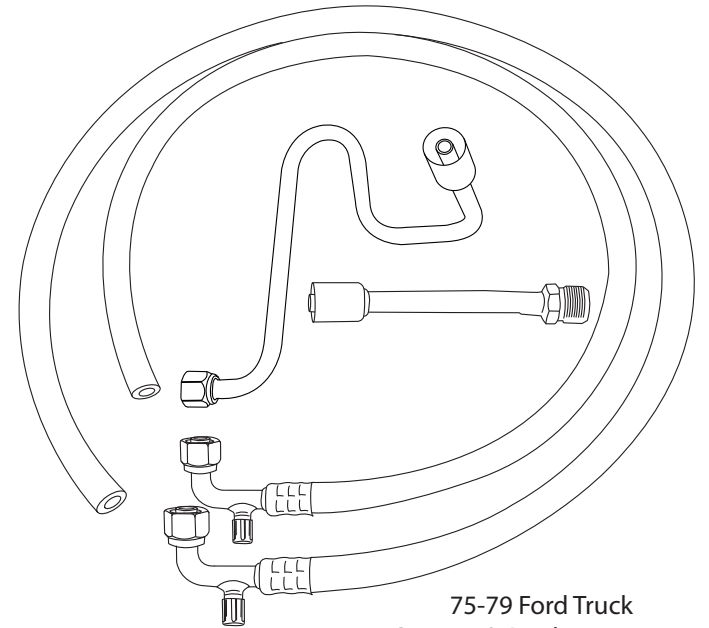

75-79 Ford Truck
Suction & Discharge Hoses
(Crimped on one end)

COMPRESSOR REMOVAL

- Disconnect the compressor clutch wire from the factory harness (**Figure 1A**).
- Remove compressor belt by loosening tensioner bolts. - *Actual idler pulley configuration may differ from image.* (**Figure 1B**).
- Disconnect both hose fittings from compressor head. (*Position loose hoses so that remaining fluid does not come in contact with painted surfaces*) (**Figure 1C**).
- Remove bolts from top compressor bracket (**Figure 1D**).
- Remove bolts from bottom compressor bracket (**Figure 1E**).
- Carefully remove the compressor from the engine brackets and engine compartment. (*Take care not to drip compressor oil on painted surfaces*)

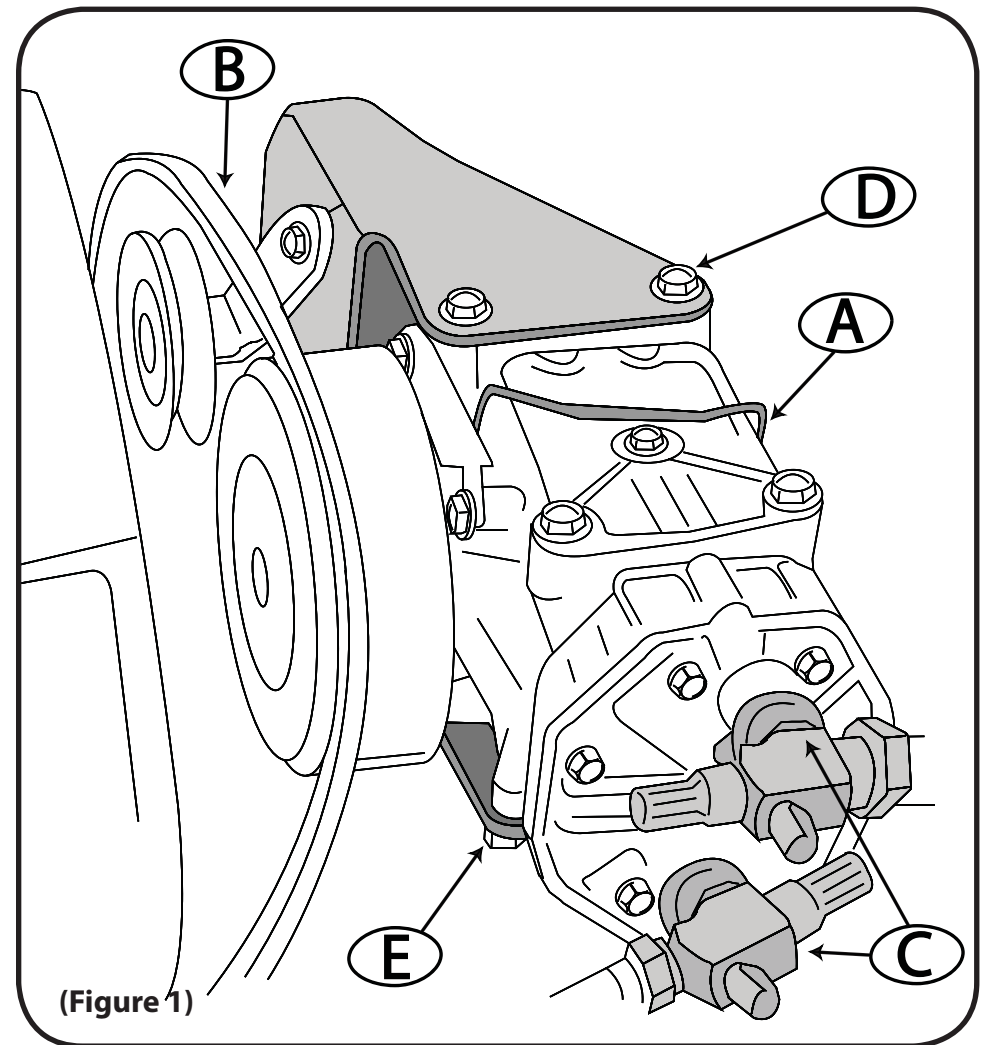

DRIER / HOSE REMOVAL

- Remove hood latch support (5 Screws) - *Condenser and drier may need to be removed together for accessibility.*
- Remove radiator support refrigerant line grommet (2 screws) **(Figure 2d)**
- Disconnect the three refrigerant lines at the drier and condenser **(Figure 2a)**
- Remove the refrigerant line bracket **(Figure 2b)**
- Remove discharge hose from vehicle (Hose going to compressor)
- Move liquid line to side.
- Remove the drier attaching bolts **(Figure 2c)**
- Separate the drier from the condenser for replacement
- Disconnect Suction hose from evaporator fitting at firewall (hose going to compressor), and remove hose.

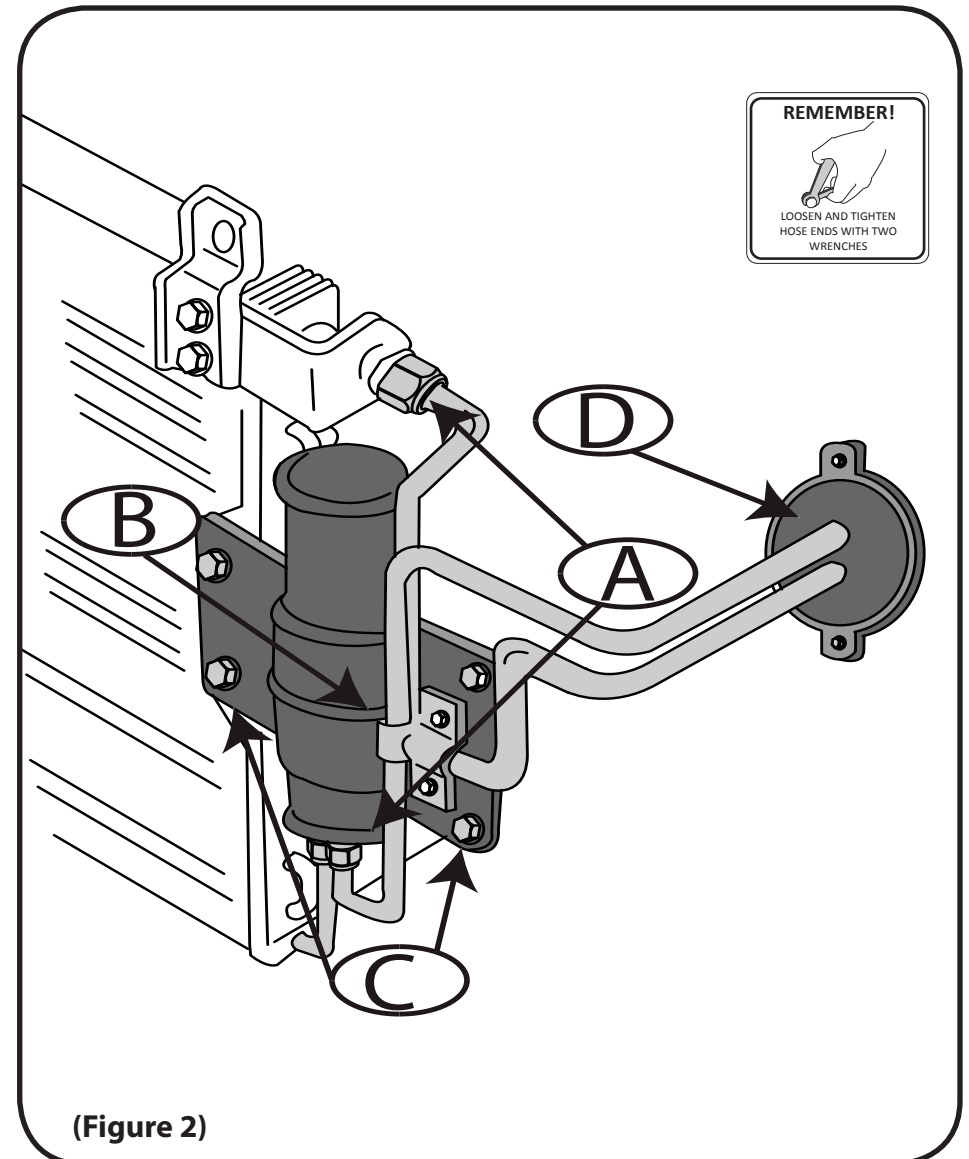

(Figure 2)

COMPRESSOR INSTALLATION

- Loosely attach the 07- 182 compressor adapter to the original bracket - See diagram included with mount. **(Figure 3a)**
- Attach the new compressor on the adapter plate loosely with included hardware. **(Figure 3b & 4a)**
- Align compressor clutch pulley with engine pulleys.
- With alignment confirmed, complete tightening of the 4 adapter plate hardware and compressor to adapter bolts. **(Figure 4b)**
- Attach the 07-183 idler adapter to the top of the factory compressor mount using the included hardware. **(Figure 5a & 4c)**
- Spacer will attach in between the compressor and 07- 183 bracket **(Figure 5b)**

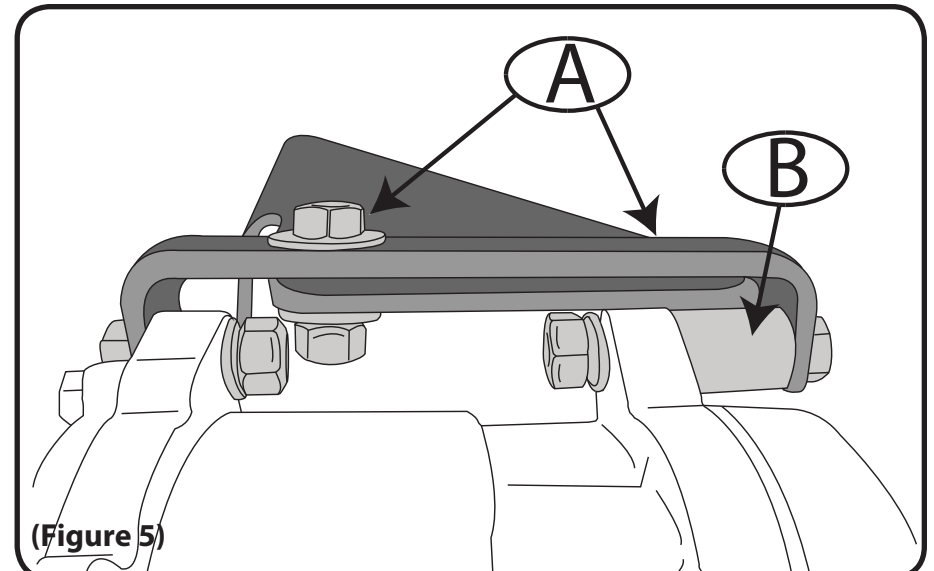
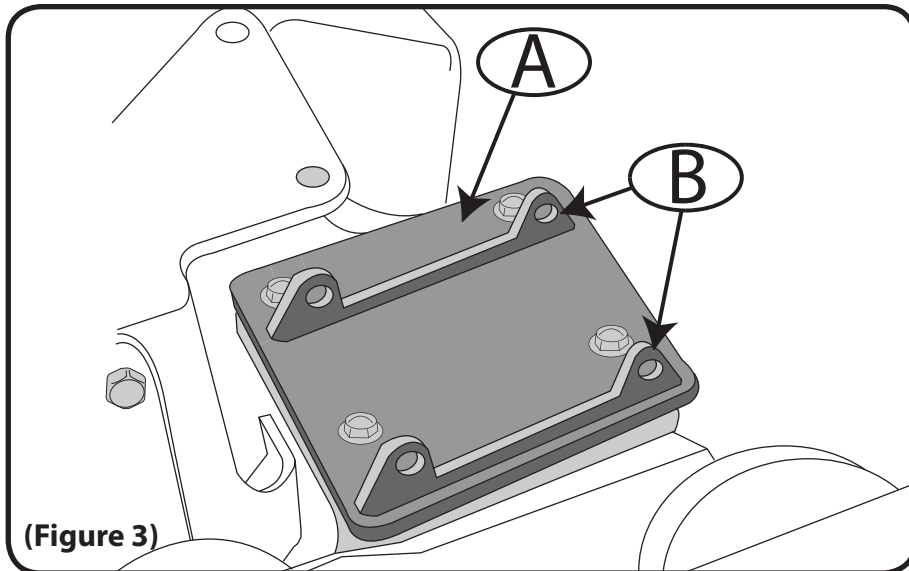
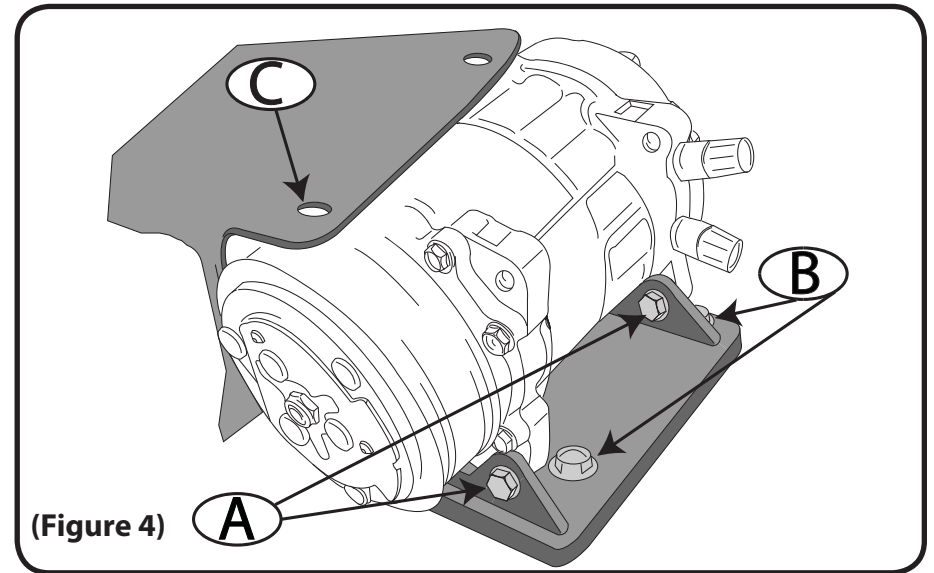



READ BEFORE PROCEEDING

PLEASE NOTE! IN ORDER TO PROTECT NEWLY INSTALLED PARTS, IT'S CRITICAL THAT THE EVAPORATOR, LIQUID LINE AND CONDENSER ARE CLEAN AND FREE OF CONTAMINATION. DAMAGE TO COMPONENTS AS A RESULT OF CONTAMINATION WILL NOT BE COVERED UNDER WARRANTY.



HOSE CONNECTION

The hoses provided in your kit will have 1 loose end that will need to be aligned and crimped. See attached crimping instructions for details.

- Attach the Suction hose fitting to evaporator outlet fitting on the firewall. Be sure to lubricate the O-ring with included oil before tightening fitting.
- Route the Suction hose to the "S" (Larger) port of the compressor and attach the fitting. Be sure to lubricate the O-ring with included oil before tightening fitting.

- Connect the Discharge hose to the "D" (Smaller) port of the compressor. Be sure to lubricate the O-ring with included oil before tightening fit.

DRIER INSTALLATION

- Replace O rings on Liquid Line & Lower Condenser fitting. Be sure to lubricate the O-ring with included oil before tightening fitting.
- Position the new drier in original location. Loosely install the drier bolts. **(Figure 2c)**
- Loosely attach the condenser liquid fitting to the drier. Be sure to lubricate the O-ring with included oil before tightening fitting.
- Loosely install the liquid line fitting to the drier. Be sure to lubricate the O-ring with included oil before tightening fitting.
- Tighten all the fittings on drier.
- Route the Discharge hose through the radiator support refrigerant line grommet. **(Figure 2d)**
- Re-attach grommet to the radiator support. **(Figure 2d)**
- Connect the Discharge hose fitting to the top fitting of the condenser. Be sure to lubricate the O-ring with included oil before tightening fitting.
- Loosely attach the tubing bracket. **(Figure 2b)**
- Tighten all the drier mounting bolts and tubing bracket.
- Reattach hood latch support.



FINAL STEPS

Take a look around at your installation and check all fittings and bolts for tightness, and make sure nothing is routed in a way to obstruct any moving parts. You can reconnect the battery and re-install the belt at this time.

The new compressor will have a slightly smaller pulley than the original compressor. The original belt should fit, however you will want to check to make sure the belt is not too loose. It may be necessary to reduce the length of your belt at your local parts retailer.

Your vehicle is now ready to take to your A/C technician for the evacuation & charging process.